

2

Orbits and Navigation

TO FULLY UNDERSTAND and use satellite data it is necessary to understand the orbits in which satellites are constrained to move and the geometry with which they view the Earth. This chapter begins with a review of basic physical principles which reveal the shape of a satellite orbit and how to orient the orbital plane in space. This knowledge allows us to calculate the position of a satellite at any time. Orbit perturbations and their effects on meteorological satellite orbits are then discussed. Next the geometry of satellite tracking and Earth location of the measurements made from the satellites are explored. This leads to a discussion of space-time sampling. The chapter concludes with a brief overview of satellite launch vehicles and orbit insertion options.

2.1 NEWTON'S LAWS

Isaac Newton¹ discovered the basic principles that govern the motions of satellites and other heavenly bodies.

¹ English physicist and mathematician, 1642–1727.

Newton's Laws of Motion

1. Every body will continue in its state of rest or of uniform motion in a straight line except insofar as it is compelled to change that state by an impressed force.
2. The rate of change of momentum is proportional to the impressed force and takes place in the line in which the force acts.
3. Action and reaction are equal and opposite.

Since momentum is the product of the mass of a body and its velocity, Newton's Second Law is the familiar

$$F = ma = m \frac{dv}{dt}, \quad (2.1)$$

where F is force, m is mass, a is acceleration, v is velocity, and t is time. In addition, Newton gave us the functional form of the force that determines satellite motion:

Newton's Law of Universal Gravitation

The force of attraction between two point masses m_1 and m_2 separated by a distance r is

$$F = \frac{Gm_1m_2}{r^2}, \quad (2.2)$$

where G is the Newtonian (or universal) gravitation constant (see Appendix E).

Consider the simple circular orbit shown in Fig. 2.1. Assuming that the Earth is a sphere, we can treat it as a point mass. The centripetal force required to keep the satellite in a circular orbit is mv^2/r , where v is the orbital velocity of the satellite. The force of gravity that supplies this centripetal force is $Gm_e m/r^2$, where m_e is the mass of the Earth (Appendix E) and m is the mass of the satellite. Equating the two forces gives

$$\frac{mv^2}{r} = \frac{Gm_e m}{r^2}. \quad (2.3)$$

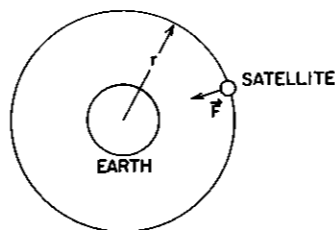

FIGURE 2.1. A circular satellite orbit.

Division by m eliminates the mass of the satellite from the equation, which means that the orbit of a satellite is independent of its mass. The *period* of the satellite is the orbit circumference divided by the velocity: $T = 2\pi r/v$. Substituting in Eq. 2.3 gives

$$T^2 = \frac{4\pi^2}{Gm_e} r^3. \quad (2.4)$$

The current NOAA satellites orbit at approximately 850 km above the Earth's surface.² Since the equatorial radius of the Earth is about 6378 km, the orbit radius is about 7228 km. Substituting in Eq. 2.4 shows that the NOAA satellites have a period of about 102 min.

As a second example, we calculate the radius required for a satellite in *geosynchronous* orbit, that is an orbit in which the satellite has the same angular velocity as the Earth. The angular velocity of a satellite is

$$\xi = \frac{2\pi}{T}. \quad (2.5)$$

Substituting Eq. 2.5 in Eq. 2.4 gives

$$r^3 = \frac{Gm_e}{\xi^2}. \quad (2.6)$$

Inserting the angular velocity of the Earth (Appendix E), the required radius for a geosynchronous orbit is 42,164 km, or about 35,786 km above the Earth's surface.

2.2 KEPLERIAN ORBITS

Satellites, however, do not travel in perfect circles, although a circular orbit is the goal for most meteorological satellites. It is possible to derive the exact form of a satellite's orbit from Newton's laws of motion and the law of universal gravitation.³ The results of this derivation are neatly summarized in Kepler's laws and in Kepler's equation.

2.2.1 Kepler's Laws

Johannes Kepler⁴ died 12 years before Newton was born and, therefore, did not have the advantage of Newton's work. Kepler formulated his laws by analyzing a mass of data on the position of the planets. This task was complicated by the rotation of the Earth and the motion of the Earth about the sun, which make

² Specifications call for them to orbit at either 833 or 870 km; 850 km is a representative value.

³ The reader is referred to Escobal (1965) and Goldstein (1950) for two quite different, but equally lengthy, derivations.

⁴ German astronomer, 1571–1630.

planetary motions seem very complex. In modern form, Kepler's laws may be stated as follows:

Kepler's Laws

1. All planets travel in elliptical paths with the sun at one focus.
2. The radius vector from the sun to a planet sweeps out equal areas in equal times.
3. The ratio of the square of the period of revolution of a planet to the cube of its semimajor axis is the same for all planets revolving around the sun.

The same laws apply if we substitute *satellite* for *planet* and *Earth* for *sun*. Equation 2.4 is a statement of Kepler's third law for the special case of a circular orbit.

2.2.2 Ellipse Geometry

The parameters that are used to specify satellite orbits are based in part on geometric terminology. Figure 2.2 illustrates the geometry of an elliptical orbit. The point where the satellite most closely approaches the Earth is the *perigee*, or more generally, the *perifocus*. The point where the satellite is furthest from the Earth is called the *apogee* or *apofocus*. The distance from the center of the ellipse to the perigee (or apogee) is the *semimajor axis* and will be denoted by the symbol a . The distance from the center of the ellipse to one focus (to the center of the Earth) divided by the semimajor axis is the *eccentricity* and will be denoted by the symbol ϵ . For an ellipse, the eccentricity is a number between zero and one ($0 \leq \epsilon < 1$). A circle is an ellipse with zero eccentricity. The equation for the ellipse, that is, the path that the satellite follows, is given in polar coordinates

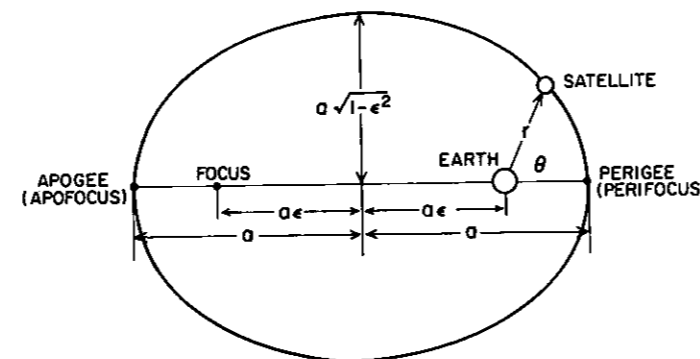

FIGURE 2.2. Elliptical orbit geometry.

with the Earth as origin as

$$r = \frac{a(1 - \epsilon^2)}{1 + \epsilon \cos\theta} \quad (2.7)$$

The angle θ is the *true anomaly* and is always measured counterclockwise (the direction of satellite motion) from the perigee.

2.2.3 Kepler's Equation

A satellite in a circular orbit undergoes uniform angular velocity. By Kepler's Second Law, however, a satellite in an elliptical orbit cannot have uniform angular velocity; it must travel faster when it is closer to Earth. The position of the satellite as a function of time can be found by applying Kepler's equation:

$$M = n(t - t_p) = e - \epsilon \sin e, \quad (2.8)$$

where M is the *mean anomaly*; M increases linearly in time at the rate n , called the *mean motion constant*, given by

$$n = \frac{2\pi}{T} = \sqrt{\frac{Gm_e}{a^3}} \quad (2.9)$$

By definition M is zero when the satellite is at perigee; therefore, t_p is the time of perigee passage. The angle e is the *eccentric anomaly*. It is geometrically related to the *true anomaly* (Fig. 2.3):

$$\cos\theta = \frac{\cos e - \epsilon}{1 - \epsilon \cos e}, \quad (2.10a)$$

$$\cos e = \frac{\cos\theta + \epsilon}{1 + \epsilon \cos\theta} \quad (2.10b)$$

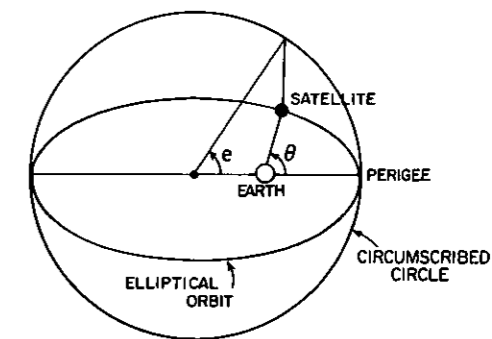

FIGURE 2.3. The geometric relationship between true anomaly (θ) and eccentric anomaly (e).

2.2.4 Orientation in Space

By calculating r and θ at time t , we have positioned the satellite in the plane of its orbit; now we must position the orbital plane in space. To do so requires the definition of a coordinate system. This coordinate system must be an *inertial coordinate system*, that is, a nonaccelerating system in which Newton's Laws of Motion are valid. A coordinate system fixed to the rotating Earth is not such a system. We will adopt an astronomical coordinate system called the *right ascension–declination coordinate system*.⁵ In this system (Fig. 2.4) the z axis is aligned with the Earth's spin axis. The x axis is chosen such that it points from the center of the Earth to the sun at the moment of the *vernal equinox*, when the sun is crossing the equatorial plane from the Southern Hemisphere to the Northern Hemisphere.⁶ The y axis is chosen to make it a right-handed coordinate system. In this system, the *declination* of a point in space is its angular displacement measured northward from the equatorial plane, and the *right ascension* is the angular displacement, measured counterclockwise from the x axis, of the projection of the point in the equatorial plane (Fig. 2.5).

Three angles are used to position an elliptical orbit in the right ascension–declination coordinate system (Fig. 2.6): the inclination angle, the right ascension of ascending node, and the argument of perigee.

The *inclination angle* (i) is the angle between the equatorial plane and the orbital plane. By convention, the inclination angle is zero if the orbital plane coincides with the equatorial plane and if the satellite rotates in the same direction as the Earth. If the two planes coincide but the satellite rotates opposite to the Earth, the inclination angle is 180° . *Prograde* orbits are those with inclination angles less than 90° ; *retrograde* orbits are those with i greater than 90° .

The *ascending node* is the point where the satellite crosses the equatorial plane going north (*ascends*). The right ascension of this point is the *right ascension of ascending node* (Ω). It is measured in the equatorial plane from the x axis (vernal equinox) to the ascending node. In practice, the right ascension of ascending node has a more general meaning. It is the right ascension of the intersection of the orbital plane with the equatorial plane; thus it is always defined, not just when the satellite is at an ascending node.

Finally, the *argument of perigee* (ω) is the angle measured in the orbital plane between the ascending node (equatorial plane) and the perigee.

⁵ Because the origin of this coordinate system moves about the sun with the Earth, it is not truly inertial. However, the sun's gravity causes the satellite to rotate around the sun as does the Earth. Therefore, the satellite acts as if the right ascension–declination coordinate system were inertial.

⁶ This x axis is also referred to as the *First Point of Aries* because it used to point at the constellation Aries. Because of the influence of the sun and moon on the nonspherical Earth, the Earth's spin axis precesses like a top with a period of 25,781 years. This causes the vernal equinox to change. Today, the x axis points to the constellation Pisces, but it is still referred to as the First Point of Aries.

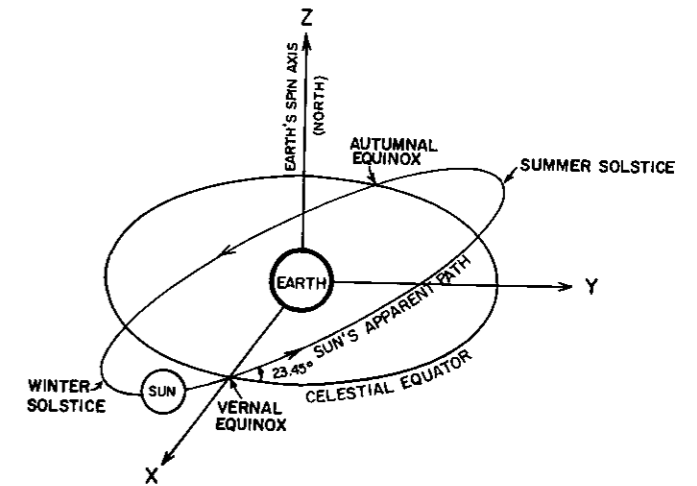

FIGURE 2.4. The right ascension–declination coordinate system.

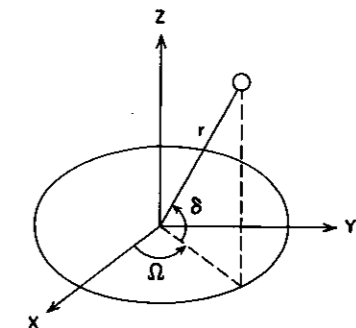

FIGURE 2.5. Coordinates used in the right ascension–declination coordinate system: right ascension (Ω), declination (δ), and radius (r).

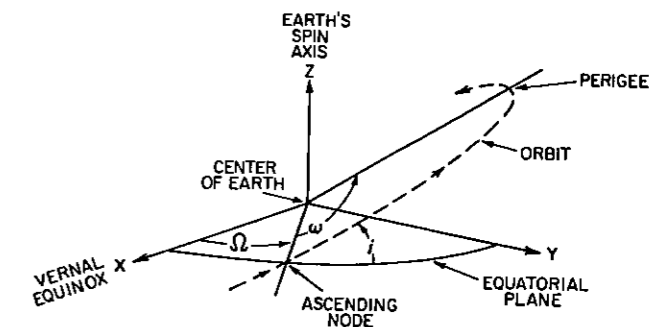

FIGURE 2.6. Angles used to orient an orbit in space.

2.2.5 Orbital Elements

The just-discussed parameters for location of a satellite in space are collectively known as the *classical orbital elements* (Table 2.1) or as *Brouwer mean orbital elements* (Brouwer and Clemence, 1961). These parameters may be determined by optical, radar, or radio ranging observations or by matching features of known locations on the Earth's surface (*landmarks*) with observations made by instruments on the satellite (Dubyago, 1961; Escobal, 1965). The orbital elements for particular satellites are available from the agencies that operate them: NOAA or NASA in the United States,⁷ the European Space Agency (ESA) in Europe, etc. A final parameter, included in Table 2.1, is the time when these elements are observed or are "valid." This time is called the *epoch time* (t_0). Some of the orbital elements change with time, as we shall see below. A subscript "o" on an orbital element indicates a value at the epoch time.

There is some variation in how the orbital elements are specified. ESA, for example, substitutes true anomaly for mean anomaly. Also, in less formal descriptions of satellite orbits, one frequently sees the height of the satellite above the Earth's surface substituted for the semimajor axis. Since the Earth is not round, the height of a satellite will vary according to its position in the orbit. Specifying the semimajor axis is a much better way to describe a satellite orbit.

Orbits in which the classical orbital elements (except M) are constant are called *Keplerian orbits*. Viewed from space, Keplerian orbits are simple. The satellite moves in an elliptical path with the center of the Earth at one focus. The ellipse maintains a constant size, shape, and orientation with respect to the stars (Fig 2.7a). Perhaps surprisingly, the only effect of the sun's gravity on the satellite is to move the focus of the ellipse (the Earth) in an elliptical path around the sun (the Earth's orbit).

Viewed from the Earth, Keplerian orbits appear complicated because the Earth rotates on its axis as the satellite orbits the Earth (Fig. 2.8). The rotation of the Earth beneath a fixed orbit results in two daily passes of the satellite near a point on the Earth (assuming that the period is substantially less than a day and that the inclination angle is greater than the latitude of the point). One pass occurs during the ascending portion of the orbit; the other occurs during the descending portion of the orbit. This usually means that one pass occurs during daylight and one during darkness.

2.3 ORBIT PERTURBATIONS

Although satellites travel in nearly Keplerian orbits, these orbits are perturbed by a variety of forces (Table 2.2). Forces arising from the last five processes are small and can be viewed as causing essentially random perturbations in the orbital elements. Operationally they are dealt with simply by periodically (1) observing

⁷ NOAA orbital elements for the polar-orbiting satellites are broadcast in the form of "TBUS bulletins." Barnes and Smallwood (1982) explain how to interpret these bulletins.

TABLE 2.1. Classical Orbital Elements

Element	Symbol
Semimajor axis	a
Eccentricity	ϵ
Inclination	i
Argument of perigee	ω_0
Right ascension of ascending node	Ω_0
Mean anomaly	M_0
Epoch time	t_0

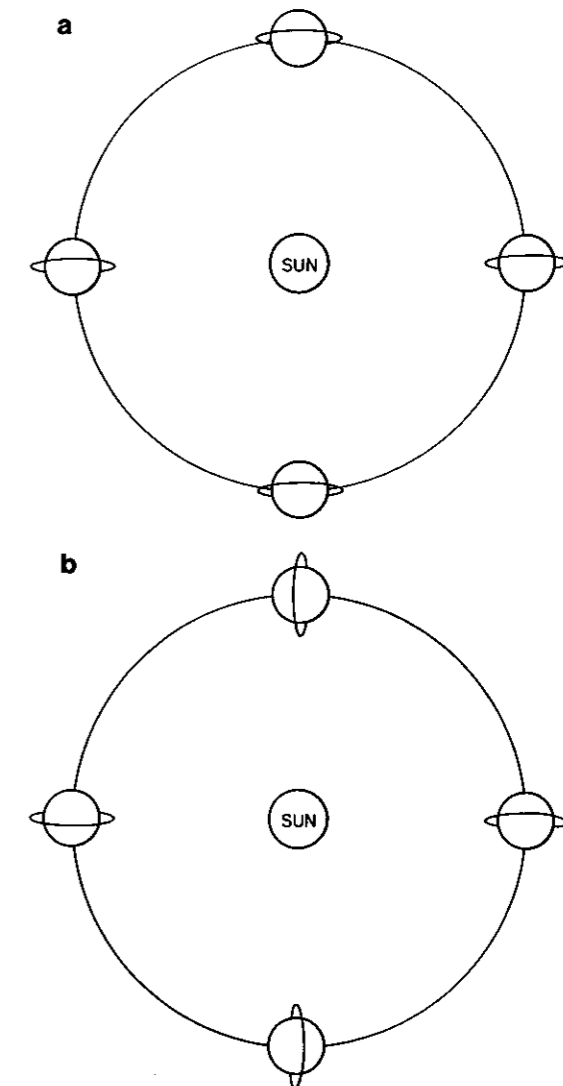

FIGURE 2.7. The change with season of (a) a Keplerian orbit and (b) a sunsynchronous orbit.

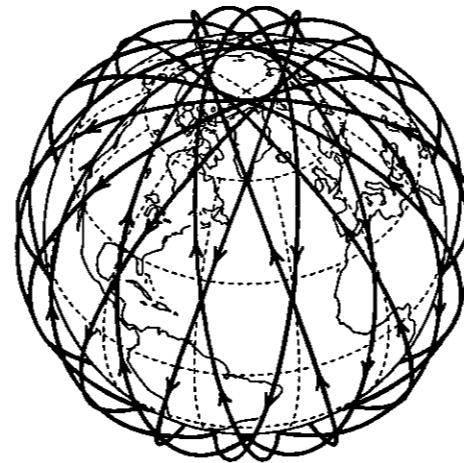

FIGURE 2.8. The orbit of a representative satellite as viewed from a point rotating with the Earth.

the orbital elements and (2) adjusting the orbit with on-board thrusters. Forces due to the nonspherical Earth cause secular (linear with time) changes in the orbital elements. These forces can be predicted theoretically and indeed are useful.

The gravitational potential of Earth is a complicated function of the Earth's shape, the distribution of land and ocean, and even the density of crustal material. As a first-order correction to a spherical shape, we may treat the Earth as an oblate spheroid of revolution. In cross section the Earth is approximately elliptical. The distance from the center of the Earth to the equator is, on average, 6378.140 km, whereas the distance to the poles is 6356.755 km. One can think of the Earth as a sphere with a 21-km-thick "belt" around the equator. The gravitational potential of the Earth is approximately given by

$$U = -\frac{Gm_c}{r} \left[1 + \frac{1}{2} J_2 \left(\frac{r_{ee}}{r} \right)^2 (1 - 3 \sin^2 \delta) + \dots \right], \quad (2.11)$$

where r_{ee} is the equatorial radius of the Earth, δ is the declination angle, and J_2 is the coefficient of the quadrupole term (Appendix E). The higher-order

TABLE 2.2. Orbit Perturbing Forces

Force	Source
Nonspherical gravitational field	Nonspherical, nonhomogeneous Earth
Gravitational attraction of auxiliary bodies	Moon, planets
Radiation pressure	Sun's radiation
Particle flux	Solar wind
Lift and drag	Residual atmosphere
Electromagnetic forces	Interaction of electrical currents in the satellite with the Earth's magnetic field

terms are more than two orders of magnitude smaller than the quadrupole term and will not be considered here, although they are necessary for very accurate calculations.

How does this belt of extra mass affect a satellite's orbit? One might expect it to cause the satellite to orbit at a different speed, and indeed it does. The time rate of change of the mean anomaly (dM/dt) is given by the mean motion constant n in the unperturbed orbit and by the *anomalous mean motion constant*, \bar{n} , in a perturbed orbit. Considering only the quadrupole term, Escobal (1965) shows that

$$\frac{dM}{dt} = \bar{n} = n \left[1 + \frac{3}{2} J_2 \left(\frac{r_{ee}}{a} \right)^2 (1 - \epsilon^2)^{-3/2} \left(1 - \frac{3}{2} \sin^2 i \right) \right]. \quad (2.12)$$

When the inclination angle is less than 54.7° , \bar{n} is greater than n ; the satellite orbits faster than it would in an unperturbed orbit. However, for larger inclinations, the satellite orbits more slowly than it otherwise would.

Because the belt exerts an equatorward force, one might also expect that it would have an effect on the inclination angle. This force, however, affects the right ascension of the ascending node rather than the inclination angle. Just as the force of gravity causes a top to precess rather than to fall over, so the attraction of the belt causes the orbit to precess about the z axis rather than to change its inclination angle. Escobal (1965) gives the rate of change of the right ascension of ascending node as

$$\frac{d\Omega}{dt} = -\bar{n} \left[\frac{3}{2} J_2 \left(\frac{r_{ee}}{a} \right)^2 (1 - \epsilon^2)^{-2} \cos i \right]. \quad (2.13)$$

The final effect of the belt is to cause the argument of perigee to rotate or precess. Escobal (1965) gives

$$\frac{d\omega}{dt} = \bar{n} \left[\frac{3}{2} J_2 \left(\frac{r_{ee}}{a} \right)^2 (1 - \epsilon^2)^{-2} \left(2 - \frac{5}{2} \sin^2 i \right) \right]. \quad (2.14)$$

The other three orbital elements, a , ϵ , and i , undergo small, oscillatory changes that may be neglected.

If SI Units are used, Eqs. 2.9, 2.12, 2.13, and 2.14 result respectively in values of n , \bar{n} , $d\Omega/dt$, and $d\omega/dt$ whose units are radians per second. The *anomalous period* of a perturbed orbit is simply

$$\bar{T} = \frac{2\pi}{\bar{n}}. \quad (2.15)$$

However, because M is measured from perigee, the anomalous period is the time for the satellite to travel from perigee to moving perigee. Of more use is the *synodic or nodal period*, \bar{T} , which is the time for the satellite to travel from one ascending node to the next ascending node. An exact value of \bar{T} must be calculated

numerically; however, to very good approximation

$$\tilde{T} = \frac{2\pi}{\left(\bar{n} + \frac{d\omega}{dt}\right)} \quad (2.16)$$

In summary, then, the first-order effects of the nonspherical gravitational potential of the Earth consist of a slow, linear change in two of the classical orbital elements, the right ascension of ascending node and the argument of perigee, and a small change in the mean motion constant.

2.4 METEOROLOGICAL SATELLITE ORBITS

Nearly all present meteorological satellites are in one of two orbits, sunsynchronous or geostationary, but other orbits are also useful.

2.4.1 Sunsynchronous Orbits

The nonspherical gravitational perturbation of Earth, far from being a problem, has a very useful application. As shown in Fig. 2.7a, the angle between the lines that join the sun and the ascending node to the center of the Earth changes in a Keplerian orbit because the orbital plane is fixed while the Earth rotates around the sun. This causes the satellite to pass over an area at different times of the day. For example, if the satellite passes over near noon and midnight in the spring, it will pass over near 6:00 am and 6:00 pm in the winter. Several problems result; among them are (1) the data do not fit conveniently into operational schedules, (2) orientation of solar cell panels is difficult, and (3) dawn or dusk visible images may not be as useful as images made at other times. Fortunately, the perturbations caused by the nonspherical Earth can be employed to keep the sun–Earth–satellite angle constant.

The Earth makes one complete revolution about the sun (2π radians) in one tropical year (31,556,925.9747 s). Thus the right ascension of the sun changes at the average rate of 1.991064×10^{-7} rad s⁻¹ (0.9856473° day⁻¹). If the inclination of the satellite is correctly chosen, the right ascension of its ascending node can be made to precess at this same rate. An orbit that is so synchronized with the sun is called a *sunsynchronous orbit*. For a satellite with a semimajor axis of 7228 km and zero eccentricity, Eq. 2.13 requires an inclination of 98.8° to be sunsynchronous. Figure 2.7b shows the change with season of a sunsynchronous orbit.

Because the sun–Earth–ascending node angle is constant⁸ in a sunsynchronous orbit, the satellite is often said to cross the equator at the same local time every

⁸ Apart from small changes due to the elliptical orbit of the Earth.

day. Unfortunately, *local time* is an ambiguous term. We will use it to mean

$$LT \equiv t_U + \frac{\Psi}{15^\circ}, \quad (2.17)$$

where t_U is coordinated universal time in hours and Ψ is the longitude in degrees of a particular point.⁹ *Equator crossing time* (ECT) is the local time when a satellite crosses the equator:

$$ECT \equiv t_U + \frac{\Psi_N}{15^\circ}, \quad (2.18)$$

where Ψ_N is the longitude of ascending or descending node. If

$$\Psi_{\text{sun}} = -15^\circ(t_U - 12) \quad (2.19)$$

is the longitude of the sun, and if $\Delta\Psi \equiv \Psi_N - \Psi_{\text{sun}}$, it is easy to show that

$$ECT = 12 + \frac{\Delta\Psi}{15^\circ}. \quad (2.20)$$

If $\Delta\Psi$ is constant, as it is for a sunsynchronous satellite, then ECT is constant.

Sunsynchronous satellites are classified by their ECTs. *Noon satellites* (or *noon–midnight satellites*) ascend (or descend) near noon LT (local time). They must, therefore, descend (or ascend) near local midnight. *Morning satellites* ascend (or descend) between 06 and 12 h LT, and descend (or ascend) between 18 and 24 h LT. *Afternoon satellites* ascend (or descend) between 12 and 18 h LT, and descend (or ascend) between 00 and 06 h LT.

The highest latitude reached by the subsatellite point (in any orbit) is equal to the inclination angle (or the supplement of i , in the case of retrograde orbits). Since sunsynchronous orbits reach high latitudes, they are referred to as *near-polar orbits*. This is frequently shortened to *polar orbits*, although they do not cross directly over the poles. These orbits are also called *low Earth orbits* (LEOs) to distinguish them from geostationary orbits (GEOs). Note, however, that *polar orbiter* is a general term for a satellite that passes near the poles, and *low Earth orbiter* is a general term for a satellite that orbits not far above the Earth's surface. While sunsynchronous satellites are of necessity polar orbiters and LEOs, the converse is not necessarily true.

The *ground track* of a satellite is the path of the point on the Earth's surface that is directly between the satellite and the center of the Earth (the *subsatellite point*). Figure 2.9 shows the ground track for three orbits of the sunsynchronous NOAA 11 satellite.

⁹ The other use of *local time* refers to the time on one's watch, that is, the time in a particular time zone. Time zones are defined as areas where time is agreed to be the local time (in our sense) on a particular meridian. Eastern Standard Time, for example, is the local time on the 75° west meridian ($\Psi = -75^\circ$).

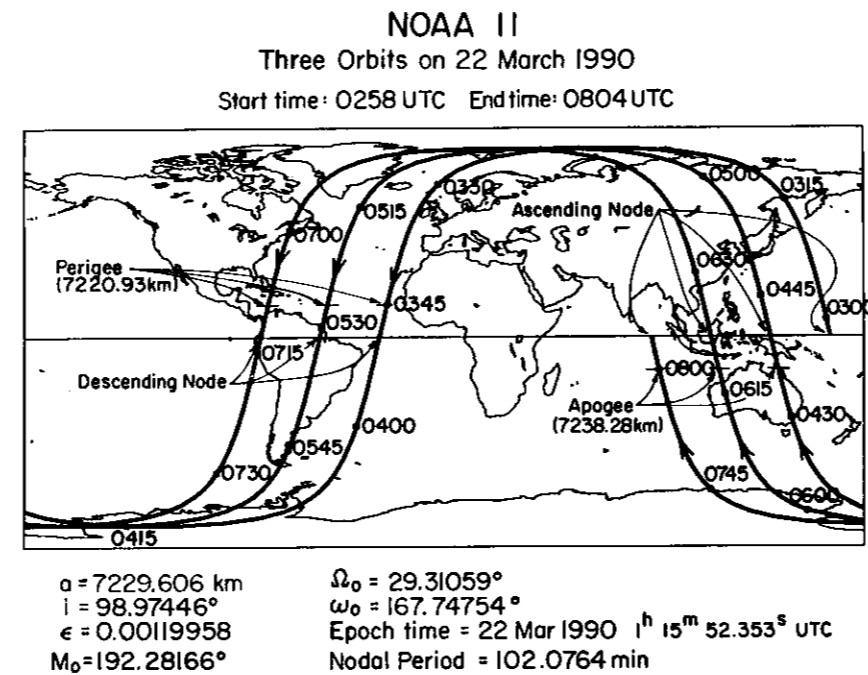

FIGURE 2.9. The ground track of a typical sunsynchronous satellite.

2.4.2 Geostationary Orbits

In Section 2.1 we calculated the radius of a geosynchronous orbit to be 42,164 km. Perturbations due to the nonspherical Earth, however, require a slight adjustment in this figure. The adjustment is small because geosynchronous orbit is about 6.6 Earth radii, and the correction terms are inversely proportional to the square of this ratio. For an orbit with zero eccentricity and zero inclination, Eqs. 2.12, 2.14, and 2.16 require a semimajor axis of 42,168 km to be geosynchronous.

The terms *geosynchronous* and *geostationary* are often used interchangeably. In fact, they are not the same. *Geosynchronous* means that the satellite orbits with the same angular velocity as the Earth. *Geostationary* orbit is geosynchronous, but it is also required to have zero inclination angle and zero eccentricity. Geostationary satellites, therefore, remain essentially motionless above a point on the equator. They are classified by the longitude of their subsatellite point.

Second-order perturbations cause a geostationary satellite to drift from the desired orbit. Periodic maneuvers, performed as frequently as once a week, are required to correct the orbit. These maneuvers keep operational geostationary satellites very close to the desired orbit. For example, on 11 March 1990, the GOES 7 satellite had an inclination angle of 0.05° ; therefore, it did not venture more than 0.05° latitude from the equator. Figure 2.10 shows the ground track for a geostationary satellite that is no longer used for imaging and therefore whose orbit is not so carefully maintained.

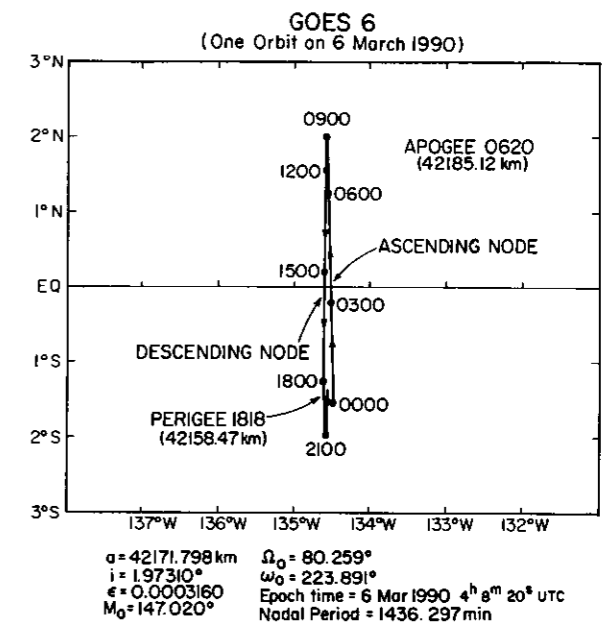

FIGURE 2.10. The ground track of a geostationary satellite. Note that the satellite's orbit is not quite geostationary; it drifts west slightly each day.

2.4.3 Other Orbits

Geostationary and sunsynchronous are only two of infinite possible orbits. Others have been and will become useful for meteorological satellites.

The Earth Radiation Budget Satellite (ERBS) was launched from the Space Shuttle and orbits at an altitude of 600 km with an inclination angle of 57° . It was placed in this orbit so that it would precess with respect to the sun and sample all local times (see Section 2.6) over the course of a month.

The former Soviet Union placed its Meteor satellites in low Earth orbit with inclination angles of about 82° (see Appendix A). The former Soviet Union also used a highly elliptical orbit for Molniya communications satellites. It has been suggested that this orbit would be useful for meteorological observations of the high latitudes (Kidder and Vonder Haar, 1990). The *Molniya orbit* has an inclination angle of 63.4° , at which the argument of perigee is motionless (Eq. 2.14); thus the apogee, from which measurements are made, stays at a given latitude. The semimajor axis is chosen such that the satellite makes two orbits while the Earth turns once with respect to the plane of the orbit. The eccentricity is made as large as possible so that the satellite will stay near apogee longer. However, the eccentricity must not be so large that the satellite encounters significant atmospheric drag at perigee. A semimajor axis of 26,554 km and an eccentricity of 0.72 result in a perigee of 7378 km (1000 km above the equator), an apogee of 45,730 km (39,352 km above the equator), and a period of 717.8 min. The

attractiveness of this orbit is that it functions as a high-latitude, part-time, nearly geostationary satellite. For about 8 h centered on apogee, the satellite is synchronized with the Earth so that it is nearly stationary in the sky. For a meteorological satellite in a Molniya orbit, the rapid imaging capability, which is so useful from geostationary orbit, would be available in the high latitudes.

As meteorological satellite instruments become more specialized, more custom orbits are likely to be used.

2.5 SATELLITE POSITIONING, TRACKING, AND NAVIGATION

It is important to be able to calculate the position of a satellite in space, to track it from Earth, and to know where its instruments are pointing. These topics are discussed in turn in this section.

2.5.1 Positioning in Space

To locate a satellite in a perturbed orbit at time t , one needs current values of the orbital elements. The three constant elements, a , e , and i , are taken directly from a recent bulletin.¹⁰ The other three, M , Ω , and ω , are calculated:

$$M = M_0 + \frac{dM}{dt}(t - t_0), \quad (2.21a)$$

$$\Omega = \Omega_0 + \frac{d\Omega}{dt}(t - t_0), \quad (2.21b)$$

$$\omega = \omega_0 + \frac{d\omega}{dt}(t - t_0). \quad (2.21c)$$

Then the satellite is positioned by one of several methods. We find two methods useful: the vector rotation method and the spherical geometry method.

2.5.1.1 The Vector Rotation Method

Figure 2.11 illustrates what we call the *vector rotation method*. It is discussed in a somewhat different form by Escobal (1965) and others. In the first step, the satellite is located in the plane of its orbit; that is, the true anomaly θ and the radius r are calculated. This is done by (1) solving for e using Eq. 2.8, (2) calculating θ using Eq. 2.10a, and (3) calculating r using Eq. 2.7. (For a circular orbit, this step is simplified because the mean anomaly, the eccentric anomaly, and the true anomaly are identical, and r is constant.)

In the second step, a vector is formed that points from the center of the Earth to the satellite in the right ascension–declination coordinate system. The Cartesian

¹⁰ Such bulletins are available from a variety of sources. Because these sources change rapidly, we suggest that the interested reader contact the agencies listed in Section 4.4 to find a convenient source of satellite bulletins.

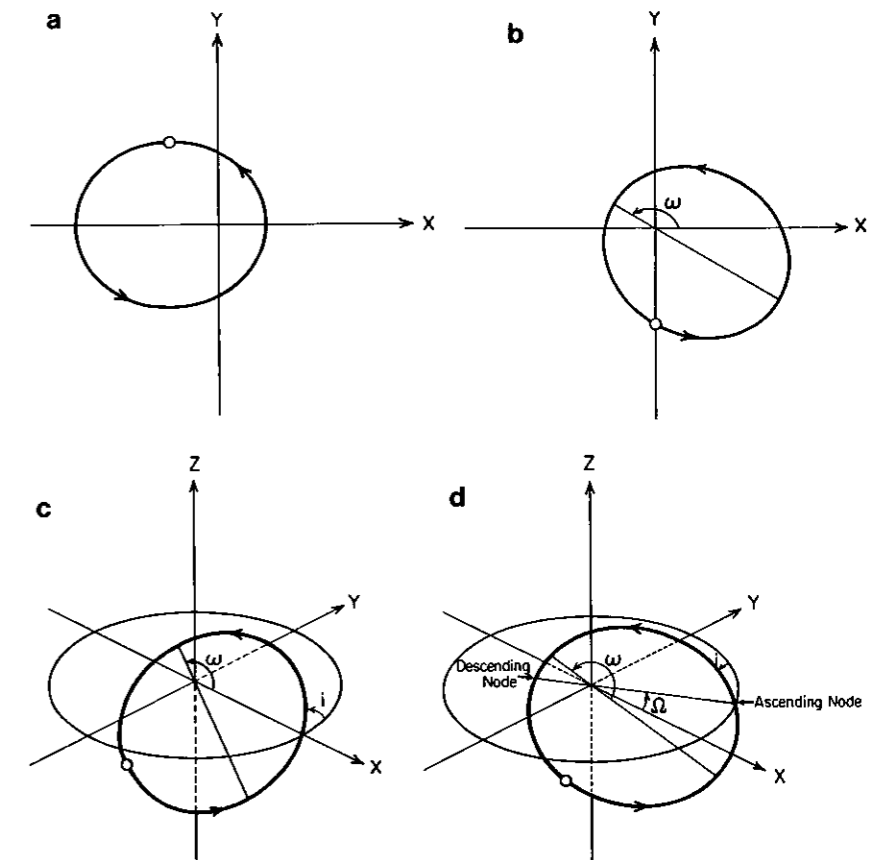

FIGURE 2.11. Rotations used to position a satellite in its orbit: (a) the satellite in the plane of its orbit, (b) rotation about the z axis through the argument of perigee (ω), (c) rotation about the x axis through the inclination angle (i), and (d) rotation about the z axis through the right ascension of ascending node (Ω).

coordinates of this vector are

$$\begin{pmatrix} x \\ y \\ z \end{pmatrix} = \begin{pmatrix} r \cos\theta \\ r \sin\theta \\ 0 \end{pmatrix}. \quad (2.22)$$

At this point, the orbital ellipse is assumed to lie in the x - y plane with the perigee on the positive x axis (Fig 2.11a).

In the final three steps, the vector is rotated so that the orbital plane is properly oriented in space.

In the third step, the vector is rotated about the z axis through the argument of perigee (Fig. 2.11b). This rotation is conveniently accomplished by multiplying

the vector by a rotation matrix, in this case

$$\begin{pmatrix} x' \\ y' \\ z' \end{pmatrix} = \begin{pmatrix} \cos\omega & -\sin\omega & 0 \\ \sin\omega & \cos\omega & 0 \\ 0 & 0 & 1 \end{pmatrix} \begin{pmatrix} x \\ y \\ z \end{pmatrix} = \begin{pmatrix} x \cos\omega - y \sin\omega \\ x \sin\omega + y \cos\omega \\ z \end{pmatrix}. \quad (2.23)$$

In the fourth step, the vector is rotated about the x axis through the inclination angle (Fig. 2.11c).

$$\begin{pmatrix} x'' \\ y'' \\ z'' \end{pmatrix} = \begin{pmatrix} 1 & 0 & 0 \\ 0 & \cos i & -\sin i \\ 0 & \sin i & \cos i \end{pmatrix} \begin{pmatrix} x' \\ y' \\ z' \end{pmatrix} = \begin{pmatrix} x' \\ y' \cos i - z' \sin i \\ y' \sin i + z' \cos i \end{pmatrix}. \quad (2.24)$$

In the fifth and final step, the vector is rotated about the z axis through the right ascension of the ascending node (Fig. 2.11d).

$$\begin{pmatrix} x''' \\ y''' \\ z''' \end{pmatrix} = \begin{pmatrix} \cos\Omega & -\sin\Omega & 0 \\ \sin\Omega & \cos\Omega & 0 \\ 0 & 0 & 1 \end{pmatrix} \begin{pmatrix} x'' \\ y'' \\ z'' \end{pmatrix} = \begin{pmatrix} x'' \cos\Omega - y'' \sin\Omega \\ x'' \sin\Omega + y'' \cos\Omega \\ z'' \end{pmatrix}. \quad (2.25)$$

The vector (x''', y''', z''') is the location of the satellite in the right ascension–declination coordinate system at time t . This vector may be converted into the radius, declination, and right ascension of the satellite by

$$r_s = \sqrt{x'''^2 + y'''^2 + z'''^2} = r, \quad (2.26a)$$

$$\delta_s = \sin^{-1} \left(\frac{z'''}{r_s} \right), \quad (2.26b)$$

$$\Omega_s = \tan^{-1} \left(\frac{y'''}{x'''} \right). \quad (2.26c)$$

After one has calculated the right ascension, declination, and radius of the satellite, it is useful to calculate the latitude and longitude of the subsatellite point. Assuming that the Earth is a sphere, the latitude (known as the *geocentric latitude*) is simply equal to the declination. The longitude of the subsatellite point is the difference between the right ascension of the satellite and the right ascension of the prime meridian (0° longitude) which passes through Greenwich, England (Fig. 2.12). The right ascension of Greenwich can be calculated knowing its right ascension at a given time and the rotation rate of the Earth.¹¹ Since the rotation rate changes very slightly, due to the actions of the wind and ocean currents, very accurate knowledge of the right ascension of Greenwich requires observations. Some satellite bulletins give the right ascension of Greenwich in addition to the satellite orbital elements.

¹¹ If nothing else is available, one can use the following: at 0000 UTC on 1 January 1990 the right ascension of Greenwich was 100.38641° , and the rotation rate was $7.292115922 \times 10^{-5}$ radians per second or 360.9856507° per day.

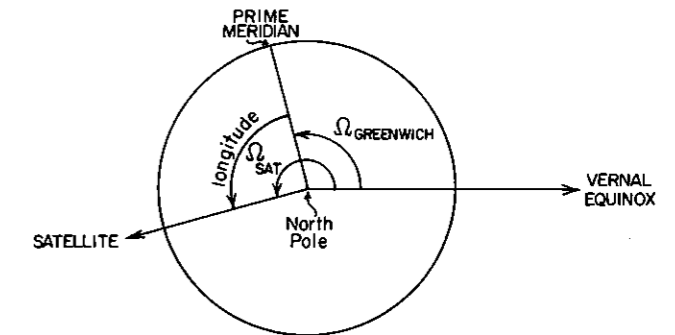

FIGURE 2.12. The relationship between Earth longitude and right ascension.

The inverse problem of finding when a satellite passes over (or close to) a particular point is solved iteratively by (1) estimating the time, (2) calculating the position of the satellite, and (3) correcting the time estimate. Steps 2 and 3 are repeated until a satisfactory solution is found.

2.5.1.2 The Spherical Geometry Method

The *spherical geometry method* can be derived using spherical geometry (Madden and Parsons, 1973), but it is also a distillation of the vector rotation method. Let Γ , the *argument of latitude*, be the angle, measured in the orbital plane, from the ascending node to the satellite. Numerically,

$$\Gamma \equiv \theta + \omega, \quad (2.27)$$

where θ is the true anomaly and ω is the argument of perigee. Working through the mathematics of the vector rotation method results in¹²

$$r_s = r, \quad (2.28a)$$

$$\Theta_s = \delta_s = \sin^{-1}(\sin\Gamma \sin i), \quad (2.28b)$$

$$\Psi_s = \tan^{-1} \left(\frac{\sin\Gamma \cos i}{\cos\Gamma} \right) + \Omega_0 - \Omega_c(t_0) - \left(\frac{d\Omega_c}{dt} - \frac{d\Omega}{dt} \right) (t - t_0). \quad (2.28c)$$

Here r is the distance of the satellite calculated with Eq. 2.7; Θ_s and Ψ_s are its latitude and longitude, respectively. $\Omega_c(t_0)$ is the right ascension of Greenwich at the epoch time, and therefore, $\Omega_0 - \Omega_c(t_0)$ is the longitude of ascending node at the epoch time. The quantity $(d\Omega_c/dt - d\Omega/dt)$ is the *relative Earth rotation rate*, that is, the rotation rate of the Earth relative to the orbital plane. For a sunsynchronous satellite, it must be exactly 2π radians per day.

¹² Normally the arctangent term would be written $\tan^{-1}(\tan\Gamma \cos i)$. The form in Eq. 2.28c is used because it allows the quadrant of the angle to be determined unambiguously. In Fortran, for example, $\text{ATAN2}(\sin\Gamma \cos i, \cos\Gamma)$ will result in the correct angle.

For a circular orbit, or one which is so nearly circular that no significant error occurs from neglecting its elliptical nature,

$$\Gamma(t) = \Gamma_o + \left(\bar{n} + \frac{d\omega}{dt} \right) (t - t_o), \quad (2.29)$$

and the spherical geometry method is particularly easy to apply. Polar orbiters can often be treated with this approximation. When they are so treated, the orbital parameters may come in a different form. The supplied parameters may be (1) the longitude of ascending node, (2) the nodal period, (3) the radius (or semimajor axis), (4) the inclination, (5) the time of ascending node, and (6) the nodal longitude increment (ΔLON), which is the difference in longitude¹³ between successive ascending nodes:

$$\Delta\text{LON} = \left(\frac{d\Omega_e}{dt} - \frac{d\Omega}{dt} \right) \tilde{T}, \quad (2.30)$$

where \tilde{T} is the nodal period. The above equations still apply, but one must remember that $\Gamma_o = 0$, $(\bar{n} + d\omega/dt) = 2\pi/\tilde{T}$, and $(d\Omega_e/dt - d\Omega/dt) = \Delta\text{LON}/\tilde{T}$.

2.5.2 Tracking

A list of time versus position of a celestial body is called an *ephemeris* (plural: *ephemerides*). To *track* a satellite, one must be able to point one's antenna at it. The *elevation angle*, measured from the local horizontal, and the *azimuth angle*, measured clockwise from the north, can be calculated from the ephemeris data as follows.

Suppose the subsatellite point is at latitude Θ_s and longitude Ψ_s , and that the satellite is at radius r_s from the center of the Earth. Suppose also that the antenna is located at latitude Θ_e , longitude Ψ_e , and radius r_e (the radius of the Earth). The Cartesian coordinates of the satellite, then, are

$$\vec{r}_s = \begin{pmatrix} x_s \\ y_s \\ z_s \end{pmatrix} = \begin{pmatrix} r_s \cos\Theta_s \cos\Psi_s \\ r_s \cos\Theta_s \sin\Psi_s \\ r_s \sin\Theta_s \end{pmatrix}, \quad (2.31)$$

whereas the Cartesian coordinates of the antenna are

$$\vec{r}_e = \begin{pmatrix} x_e \\ y_e \\ z_e \end{pmatrix} = \begin{pmatrix} r_e \cos\Theta_e \cos\Psi_e \\ r_e \cos\Theta_e \sin\Psi_e \\ r_e \sin\Theta_e \end{pmatrix}. \quad (2.32)$$

The difference vector ($\vec{r}_D \equiv \vec{r}_s - \vec{r}_e$) points from the antenna to the satellite (Fig. 2.13). Assuming a spherical Earth, the vector \vec{r}_e points to the local vertical (Fig.

¹³ That is, the next ascending node occurs ΔLON west of the current ascending node.

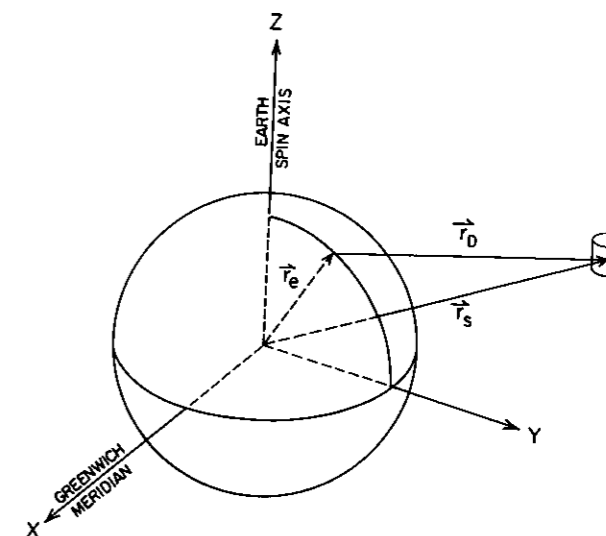

FIGURE 2.13. Satellite tracking geometry.

2.14). The cosine of the satellite's *zenith angle* ζ (the complement of the elevation angle) is given by

$$\cos \zeta = \frac{\vec{r}_e \cdot \vec{r}_D}{|\vec{r}_e| |\vec{r}_D|}. \quad (2.33)$$

Finding the azimuth angle is a little more difficult. First, we need to find two vectors in the tangent plane at the antenna. The first points north:

$$\vec{r}_N = \begin{pmatrix} x_N \\ y_N \\ z_N \end{pmatrix} = \begin{pmatrix} -\sin\Theta_e \cos\Psi_e \\ -\sin\Theta_e \sin\Psi_e \\ \cos\Theta_e \end{pmatrix}. \quad (2.34)$$

The second is the horizontal projection of \vec{r}_D . If we define unit vectors in the

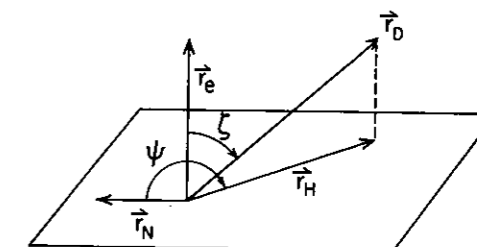

FIGURE 2.14. Definition of zenith angle (ζ) and azimuth angle (ψ).

directions of \vec{r}_e and \vec{r}_D as

$$\hat{r}_e \equiv \frac{\vec{r}_e}{|\vec{r}_e|}, \quad (2.35a)$$

$$\hat{r}_D \equiv \frac{\vec{r}_D}{|\vec{r}_D|}, \quad (2.35b)$$

the required horizontal vector is

$$\vec{r}_H = \vec{r}_D - (\hat{r}_e \cdot \vec{r}_D) \hat{r}_e = \vec{r}_D - |\vec{r}_D| \cos \zeta \hat{r}_e = |\vec{r}_D| (\hat{r}_D - \cos \zeta \hat{r}_e). \quad (2.36)$$

The azimuth angle is then given by

$$\cos \psi = \frac{\vec{r}_N \cdot \vec{r}_H}{|\vec{r}_N| |\vec{r}_H|}. \quad (2.37)$$

One must be careful when taking the inverse cosine. If the satellite is west of the antenna, ψ will be greater than 180° . It also must be noted that these equations assume a spherical Earth. Fortunately, most receiving antennas are insensitive to the slight errors this assumption causes.

2.5.3 Navigation

In addition to knowing where a satellite is in its orbit, it is necessary to know the Earth coordinates (latitude, longitude) of the particular scene it is viewing. The problem of calculating the Earth coordinates is known as the *navigation problem*; fundamentally, it is a complex geometry problem. It requires an accurate knowledge of where the satellite is in its orbit, the orientation of the satellite (its *attitude*), and the scanning geometry of the instrument involved.

In simplified form, we can proceed as follows. Suppose that at a particular time a satellite is at position (x_s, y_s, z_s) with respect to the center of the Earth in the right ascension–declination coordinate system. Suppose further, that the telescope is pointing in a direction specified by declination δ_T and right ascension Ω_T . A unit vector in the direction that the telescope is pointing is given by

$$\begin{pmatrix} x_T \\ y_T \\ z_T \end{pmatrix} = \begin{pmatrix} \cos \delta_T \cos \Omega_T \\ \cos \delta_T \sin \Omega_T \\ \sin \delta_T \end{pmatrix}. \quad (2.38)$$

Figure 2.15 shows that the ray from which the telescope receives radiation (that is, the line in space through the satellite and in the direction of the telescope) is given by

$$\begin{pmatrix} x \\ y \\ z \end{pmatrix} = \begin{pmatrix} x_s + s x_T \\ y_s + s y_T \\ z_s + s z_T \end{pmatrix}, \quad (2.39)$$

where s is the distance from the satellite.

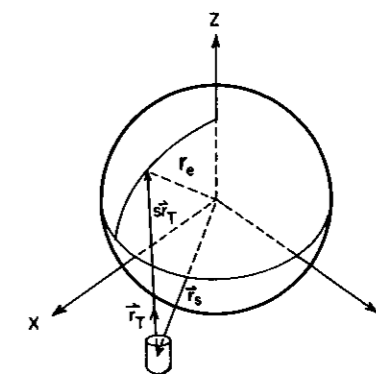

FIGURE 2.15. Navigation geometry.

The location at which this ray strikes the spherical Earth is the solution of the equation

$$(x_s + s x_T)^2 + (y_s + s y_T)^2 + (z_s + s z_T)^2 = r_e^2. \quad (2.40)$$

This is a quadratic equation in s that has no real roots, if the ray does not intersect the Earth; or two real roots, if it does. The smaller root is to be chosen; the larger root represents the location from which the ray reemerges from the opposite side of the Earth. When the ray is just tangent to the Earth, the two roots are equal.¹⁴

After a solution for s has been found, Eq. 2.39 gives the Cartesian coordinates in the right ascension–declination coordinate system of the point on the Earth's surface being viewed. The latitude and longitude can then be found as in Section 2.5.1.

Satellite images are usually the result of a scanning instrument. The data come in the form of scan lines, each divided into elements or samples known as *pixels* or *scan spots*. Because scanning is very carefully timed, each pixel has a unique time associated with it. Therefore, calculating the latitude and longitude of a pixel is accomplished using the equations of Sections 2.5.1 and 2.5.3 in the forward direction; time yields satellite position and telescope pointing angles, which then yield latitude and longitude. The opposite problem, finding the pixel which observed a particular point on Earth (latitude and longitude), must be solved in an iterative manner because the exact time when the point was observed is unknown. In brief, the time of observation is estimated, the actual point being observed at that time is calculated, and a correction is made in the time which moves the point of observation closer to the desired point. This procedure is iterated until satisfactory convergence is achieved.

The scheme outlined here for finding latitude and longitude is simple and very general. It is applicable to a wide variety of satellite orbits and instruments. For

¹⁴ For a geostationary satellite, this occurs about 81° from the satellite subpoint and explains why geostationary satellites never observe the poles.

each instrument, the difficult part is to determine the telescope pointing angles δ_T and Ω_T .

2.5.3.1 Geostationary Geometry

Until recently, all geostationary meteorological satellites were spin stabilized. They spin on an axis which is maintained nearly parallel to the Earth's spin axis. The rotation of the satellite changes the right ascension of the telescope and provides scanning across the Earth. Scanning in the north-south direction is accomplished by a tilting mirror (see Chapter 4), which changes the telescope declination. Thus δ_T and Ω_T are natural coordinates for spin-stabilized geostationary satellites.

Unfortunately, the satellite's spin axis is not exactly parallel to the Earth's spin axis. Furthermore, although the radiometer's telescope is rigidly oriented with respect to the principal axis of the satellite, the spin axis deviates slightly from the principal axis, which causes deviations similar to pitch, roll, and yaw in a low Earth orbiter (see next section). Corrections for these effects and for the non-spherical Earth can be made. The interested reader is referred to Hambrick and Phillips (1980).

The parameters that describe the satellite orbit and attitude must be accurately known to perform accurate navigation. These parameters can be determined by the use of landmarks. Normally the orbit and attitude parameters are accurate, as is navigation performed with them. However, for up to 18 h after the thrusters are fired in an orbit- or attitude-correcting maneuver, navigation parameters are poorly known, and pixels can be significantly misplaced. These errors can be partially corrected by displaying the data as an image and shifting the image up or down and right or left until a landmark is properly positioned. Rotation of the image is sometimes necessary to achieve good navigation, especially if a large (continent-size) area is being studied.

It is interesting to note that the GOES satellites can detect a few stars at the edges of the image frame. These stars can be used to very accurately determine the attitude of the satellite. Then landmarks can be used to determine the orbital elements (Hambrick and Phillips, 1980).

2.5.3.2 Low Earth Orbit Geometry

Low Earth orbit satellite instruments have many scanning patterns. Navigation of these data can be achieved using different approaches. We outline an approach, based on the discussion above, which is general enough for use with many scanning patterns. The basis of the technique is that if we can determine where a scan spot is in relation to the satellite, then we can use nearly the same rotation matrices with which we position the satellite to position the scan spot. First we must define the angles and a coordinate system used to specify satellite attitude.

The instruments on many low Earth orbit satellites are mounted on the underside of the satellite and scan perpendicular to the velocity vector through the subsatellite point (see Chapter 4). A convenient coordinate system (Fig. 2.16) is one in which the z axis points from the satellite toward the center of the Earth,

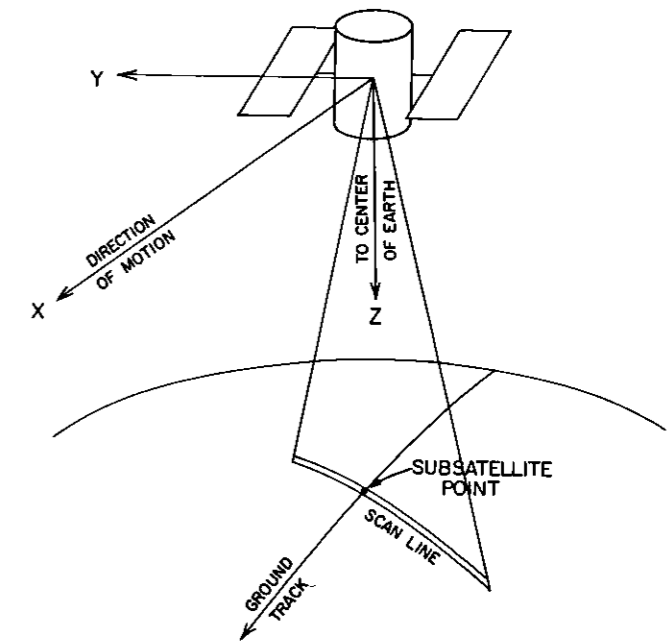

FIGURE 2.16. Coordinate system used for satellite attitude.

the x axis points in the direction of satellite motion, and the y axis is chosen to complete a right-handed coordinate system. Three angles specify the orientation of the satellite in this coordinate system. Rotation about the y axis is called *pitch*, rotation about the x axis is called *roll*, and rotation about the z axis is called *yaw*.

A combination of these angles can be used to specify nearly any scan geometry. Instruments that scan through nadir perpendicular to the satellite motion vector are described by changing the roll angle. Instruments that scan in a cone can be described by a constant pitch plus a variable yaw. Instruments that scan through the subpoint but at an oblique angle with respect to the satellite motion vector can be described with a roll plus a constant yaw.

To calculate the position of a scan spot with respect to the satellite, we proceed as follows. First, position the satellite at radius r_s , declination zero, and right ascension zero, and let its velocity vector point east. Assume that the telescope is pointing straight down,¹⁵ or $\delta_T = 0$ and $\Omega_T = \pi$. That is, the telescope pointing vector is $x_T = -1$, $y_T = 0$, $z_T = 0$. Next, rotate the telescope vector through the pitch, roll, and yaw angles that describe the position of the telescope at time t .

¹⁵ If the satellite is not pointing straight down, its deviation is described by pitch, roll, and yaw bias errors, which are usually small. For example, horizon sensors and a sun sensor on the current NOAA satellites maintain pitch, roll and yaw bias errors to within $\pm 0.2^\circ$ of zero. If the bias errors are known, and if the desired precision of the calculation requires it, the initial telescope pointing vector can be corrected for bias errors at this point.

or for the scan position desired. At the assumed position and orientation of the satellite, in the right ascension–declination coordinate system, the pitch rotation matrix is

$$\begin{pmatrix} \cos\alpha_p & \sin\alpha_p & 0 \\ -\sin\alpha_p & \cos\alpha_p & 0 \\ 0 & 0 & 1 \end{pmatrix},$$

where α_p is the pitch angle; the roll rotation matrix is

$$\begin{pmatrix} \cos\alpha_R & 0 & -\sin\alpha_R \\ 0 & 1 & 0 \\ \sin\alpha_R & 0 & \cos\alpha_R \end{pmatrix},$$

where α_R is the roll angle; and the yaw rotation matrix is

$$\begin{pmatrix} 1 & 0 & 0 \\ 0 & \cos\alpha_Y & -\sin\alpha_Y \\ 0 & \sin\alpha_Y & \cos\alpha_Y \end{pmatrix},$$

where α_Y is the yaw angle.¹⁶

After the telescope pointing vector has been determined, the distance s from the satellite to the scan spot is calculated using Eq. 2.40, and the position of the spot relative to the satellite is calculated using Eq. 2.39.

Finally, the scan spot is moved along with the satellite to its actual position by (1) rotating about the z axis through the argument of latitude, (2) rotating about the x axis through the inclination angle, and (3) rotating about the z axis through the right ascension of the ascending node minus the right ascension of Greenwich.

An advantage to this method is that if the orbit is sufficiently circular, the vectors to the scan spots can be calculated in advance and simply rotated into position at successive times.

Note that limb scanners, which scan the atmosphere above the Earth's horizon, can be treated with this procedure except that Eq. 2.40 is not applicable because the ray does not strike the Earth. Instead, the distance to the tangent point, that is, the point where the ray most closely approaches the Earth, can be used for s . If α is the angle between the initial telescope pointing vector (straight down) and the final vector, then

$$s = r_s \cos\alpha. \quad (2.41)$$

Finally, we would like to outline a simple calculation that is frequently useful in satellite meteorology: how to find the distance of a scan spot from the subsatellite

¹⁶ If the satellite is thought of as an airplane, a positive pitch angle is defined here as the nose pointing up, a positive roll as the right wing pointing up, and a positive yaw as a counterclockwise rotation of the plane as viewed from above.

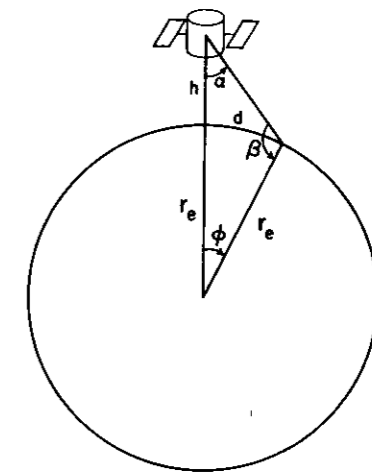

FIGURE 2.17. Determining the distance of a scan spot from the subsatellite point.

point. Figure 2.17 shows the geometry of this calculation. If α is the scan angle, then the law of sines gives the angle β as

$$\sin\beta = \left(\frac{r_s}{r_e}\right) \sin\alpha. \quad (2.42)$$

The angle measured from the center of the Earth is

$$\phi = \pi - \beta - \alpha, \quad (2.43)$$

and the distance from the subsatellite point to the scan spot is ϕr_e .

The *swath width* is the width of the entire scan of the satellite instrument. If the instrument scans equally on each side of the ground track, then the swath width is $2\phi r_e$, where α is the maximum scan angle.¹⁷

2.6 SPACE-TIME SAMPLING

To select an orbit for a satellite or a scan pattern for a particular instrument, several questions must be answered: What areas will the orbit and scan pattern allow the instrument to observe? How often will an area be observed? At what local times will the observations be made? At what viewing zenith and azimuth angles will the observations be made? These questions are all aspects of what is called *space–time sampling*.

Geostationary satellites are designed to be nearly stationary over a point on the equator. They therefore view a fixed area (about 42% of the globe). Any

¹⁷ With this definition, the swath width is the distance between the centers of the extreme scan spots (see Fig. 4.10). Sometimes, the halfwidth of the radiometer field of view is added to each end of the swath, so that the swath width describes all that the radiometer senses.

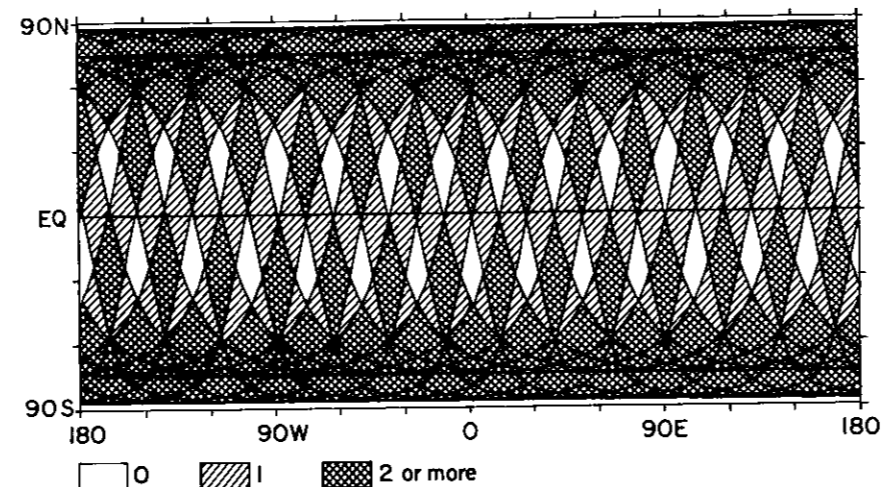

FIGURE 2.18. One day's coverage by a hypothetical instrument on a sunsynchronous satellite. The coverage at the equator is 50%. The orbit is circular with a semimajor axis of 7228 km and an inclination angle of 98.8°. Note that slightly different orbit parameters can result in quite different patterns.

point in this area can be observed as frequently as their instruments will allow; that is, it can be observed at any local time. However, since each point has a fixed geometric relationship to the satellite, it is viewed at only one zenith and one azimuth angle.

For a satellite in low Earth orbit, these questions depend on the satellite's orbit and the scanning geometry of its instruments. Most meteorological satellite instruments are designed such that the area viewed on one orbit touches or overlaps the area viewed on previous and successive orbits. If the satellite's inclination angle is large enough, the instrument views every point on Earth twice per day, at least. The poles are observed on every orbit. Usually each point is viewed at a wide range of zenith and azimuth angles. Many meteorological satellites are in sunsynchronous orbits, which have constant equator crossing times. These satellites view each point (except near the poles) only in a small range of local times ($\pm \frac{1}{2}T$) centered on the two equator crossing times.

For instruments whose scans on successive orbits do not overlap, it is often best to plot the coverage for a day and to determine visually which areas are observed and which are not. Figure 2.18, for example, shows the one-day coverage of a hypothetical instrument in a sunsynchronous orbit which has 50% coverage at the equator.¹⁸ Some areas are not observed, some are observed once, and some are observed twice or more. This pattern will be the same on succeeding days, *except that it will drift in longitude*. The drift rate can be calculated as follows. Divide the length of day by the nodal period and round to the nearest integer,

¹⁸ That is, the swath width divided by the sine of the inclination angle is 50% of ΔLON .

N . The westward longitude increment in N complete orbits is $N\Delta\text{LON}$. If we express the nodal longitude increment ΔLON (Eq. 2.30) in degrees, then the change in the pattern per day is

$$\text{Drift} = -N\Delta\text{LON} + 360^\circ. \quad (2.44)$$

Sunsynchronous satellites have a relative Earth rotation rate of exactly 360° per day. They have the interesting property that if they make an integral number of orbits in an integral number of days, then they must arrive exactly at the longitude where they started and repeat the ground track. If such a satellite makes $N + k/m$ orbits per day, where k and m are integers, then the orbit track repeats every m days after making $mN + k$ orbits. Furthermore, if k and m have no common factors, all m of the ground tracks, spaced $\Delta\text{LON}/m$, will be traversed. Earth remote sensing satellites have utilized this property. Landsats 1, 2, and 3, for example, were designed to make $13^{17}/18$ orbits per day. Thus they had a nodal period of 103.27 min, which means that ΔLON was 25.82° . The distance between ascending nodes at the equator was about 2874 km. The Multispectral Scanner (MSS) scanned across the satellite track with a ground swath width of only 185 km; only a small fraction of the equator was observed on any one day. The daily longitude drift was -1.43° ($-\Delta\text{LON}/18$), or about 160 km west of an ascending node on the previous day. Since the swath width was greater than the westward movement, the swaths on successive days overlapped. In 18 days the satellites observed every point on the equator and began the cycle anew.

The French SPOT satellites (see *SPOT User's Handbook*) utilize the same type of repeat cycle, except that they orbit $14^{5}/26$ times per day. The swaths on successive days do not overlap, but in 26 days the entire Earth is imaged. Landsats 4 and 5 have similar orbits.

Note that this repeat cycle is very sensitive to the semimajor axis. If the orbital altitude of Landsats 1, 2, and 3 had been decreased by only 19 km, they would have made exactly 14 orbits in one day. There would have been no westward progression of the swaths. Some parts of the Earth would be observed every day; the rest would never be observed.

For studies of diurnal variation, a point must be observed at local times throughout the day. Since sunsynchronous satellites view a point at nearly the same two local times every day, they are not useful for diurnal variation studies. A satellite designed specifically to measure diurnal variation is the Earth Radiation Budget Satellite (ERBS; see Chapter 10). It is in a 57° -inclination orbit at an altitude of 600 km. The right ascension of ascending node moves west by 3.955° per day, while the mean sun moves east 0.986° per day (360° in one year). Thus the angle between the sun and the ascending node changes 4.94° per day. Because the satellite makes observations both as it ascends and as it descends, all local times will be sampled when the sun-Earth-ascending node angle has changed by 180° . The ERBS, then, samples all local times in about 36 days.

Many space-time sampling strategies are possible. The reader is encouraged to use the equations presented above to investigate some of the possibilities.

2.7 LAUNCH VEHICLES AND PROFILES

A discussion of satellite orbits would not be complete without mention of the launch vehicles used and the strategies available for achieving orbit.

2.7.1 Launch Vehicles

U.S. meteorological satellites have been launched by a variety of vehicles, but recently two have predominated (Fig. 2.19). The Delta 3914 was used to place the 345-kg GOES 4-7 satellites into 35,790-km geostationary orbits. The Atlas E/F is used to boost the 1421-kg NOAA satellites into 850-km sunsynchronous orbits. Other meteorological satellites have been placed into orbit by the French Ariane rocket, the Soviet F-2 rocket, and the Japanese N-2 rocket, and the U.S. Space Shuttle (see Appendix A). As satellite launches become more commercial and more competitive, many different rockets are likely to be used for meteorological satellites.

It is interesting that a far larger rocket is used to launch the low Earth orbit satellites than the geostationary satellites. In part this is because the energy required to achieve orbit is proportional to the mass of the satellite. However, Fig. 2.20 shows that the Earth is at the bottom of a deep gravitational potential well. The first step into space is the energy-consuming step. It takes approximately 35 MJ kg^{-1} to lift a satellite into an 850 km orbit; it takes only about 65% (23 MJ kg^{-1}) additional energy to increase that orbit by a factor of 42 to geostationary altitude.

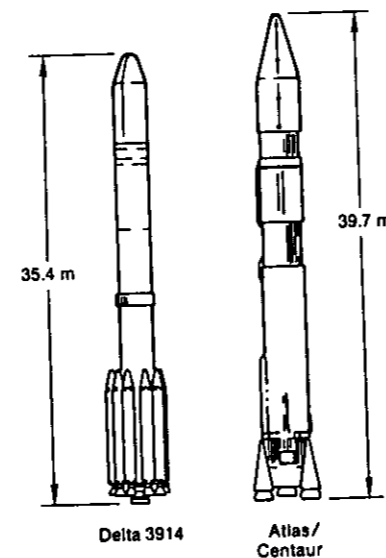

FIGURE 2.19. Rockets used to launch recent U.S. meteorological satellites. [After Chen (1985). Reprinted by permission of Academic Press.]

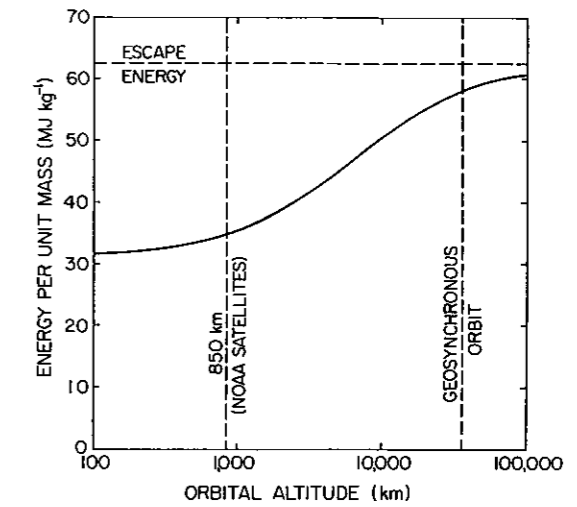

FIGURE 2.20. The energy per unit mass required to place a satellite in orbit as a function of orbital altitude. Note that the considerable energy required to lift the rocket itself is not included in this figure.

2.7.2 Launch Profiles

Three basic strategies are available for orbit insertion. In *power-all-the-way ascents* the rocket burns steadily until the desired orbit is achieved. This launch profile is more costly, but less risky, than the others because rockets do not have to be restarted in space. This profile is used for manned space flights.

The second type of launch profile is called *ballistic ascent* because of its similarity with artillery. A large first-stage rocket is used in the early part of the flight to propel the payload to high velocity. It then coasts to the location of the desired orbit, where a second-stage rocket is fired to adjust the trajectory to the desired orbit.

The third type of launch profile is called *elliptical ascent*. Orbit insertion is achieved in three steps. First the payload is placed in a low Earth orbit by either of the above means. This first orbit is referred to as a *parking orbit*. In the next phase, a rocket is fired to move the payload into an elliptical *transfer orbit* whose perigee is the parking orbit and whose apogee is the desired orbit. When the payload reaches apogee, a rocket (sometimes called an "apogee kick motor") modifies the orbit to the desired (usually circular) shape. Elliptical ascent is used for geostationary satellites.

Bibliography

- Barnes, J. C., and M. D. Smallwood (1982). *TIROS-N Series Direct Readout Services Users Guide*. NOAA, Washington, DC.
 Brouwer, D., and G. M. Clemence (1961). *Methods of Celestial Mechanics*. Academic Press, New York.
 Chen, H. S. (1985). *Space Remote Sensing Systems: An Introduction*. Academic Press, Orlando.

- Dubyago, A. D. (1961). *The Determination of Orbits*. The Macmillan Company, New York.
- Escobal, P. R. (1965). *Methods of Orbit Determination*. John Wiley and Sons, New York.
- Goldstein, H. (1950). *Classical Mechanics*. Addison-Wesley, Reading, MA.
- Hambrick, L. N., and Phillips, D. R. (1980). *Earth Locating Image Data of Spin-Stabilized Geosynchronous Satellites*. NOAA Tech. Memo. NESS 111, Washington, DC.
- Kidder, S. Q., and T. H. Vonder Haar (1990). On the use of satellites in Molniya orbits for meteorological observation of middle and high latitudes. *J. Atmos. Ocean. Tech.*, 7, 517-522.
- Madden, R., and Parsons, C. (1973). A technique for real-time, quantitative display of APT Scanning Radiometer data. *J. Appl. Meteor.*, 12, 381-385.
- Short, N. M., P. D. Lowman, Jr., S. C. Freden, and W. A. Finch, Jr. (1976). *Mission to Earth: Landsat Views the World*. NASA, Washington, DC.
- Smith, E. A. (1980). *Orbital Mechanics and Analytic Modeling of Meteorological Satellite Orbits*. Colo. State Univ. Atmos. Sci. Pap. 321, Fort Collins, CO.
- SPOT User's Handbook. SPOT Image Corp., Reston, VA.

3

Radiative Transfer

ALL OF THE information received by a satellite about the Earth and its atmosphere comes in the form of electromagnetic radiation. It is necessary, therefore, to understand the mechanisms by which this radiation is generated and how it interacts with the atmosphere. Several texts listed in the Bibliography explore atmospheric radiation in detail. Here we concentrate on those aspects that are essential for satellite meteorology.

3.1 BASIC QUANTITIES

Electromagnetic radiation consists of alternating electric and magnetic fields (Fig. 3.1). The electric field vector is perpendicular to the magnetic field vector, and the direction of propagation is perpendicular to both. Radiation is often specified by its *wavelength*, which is the distance between crests of the electric or magnetic field. Figure 3.2 shows the electromagnetic spectrum. A broad range of wavelengths from the ultraviolet to the microwave region is useful in satellite meteorology.

An alternate way to describe radiation is to give its *frequency*, which is the rate at which the electric or magnetic field oscillates when observed at a point.